

Positive displacement internal gear pumps

V and SAXMAG V Series

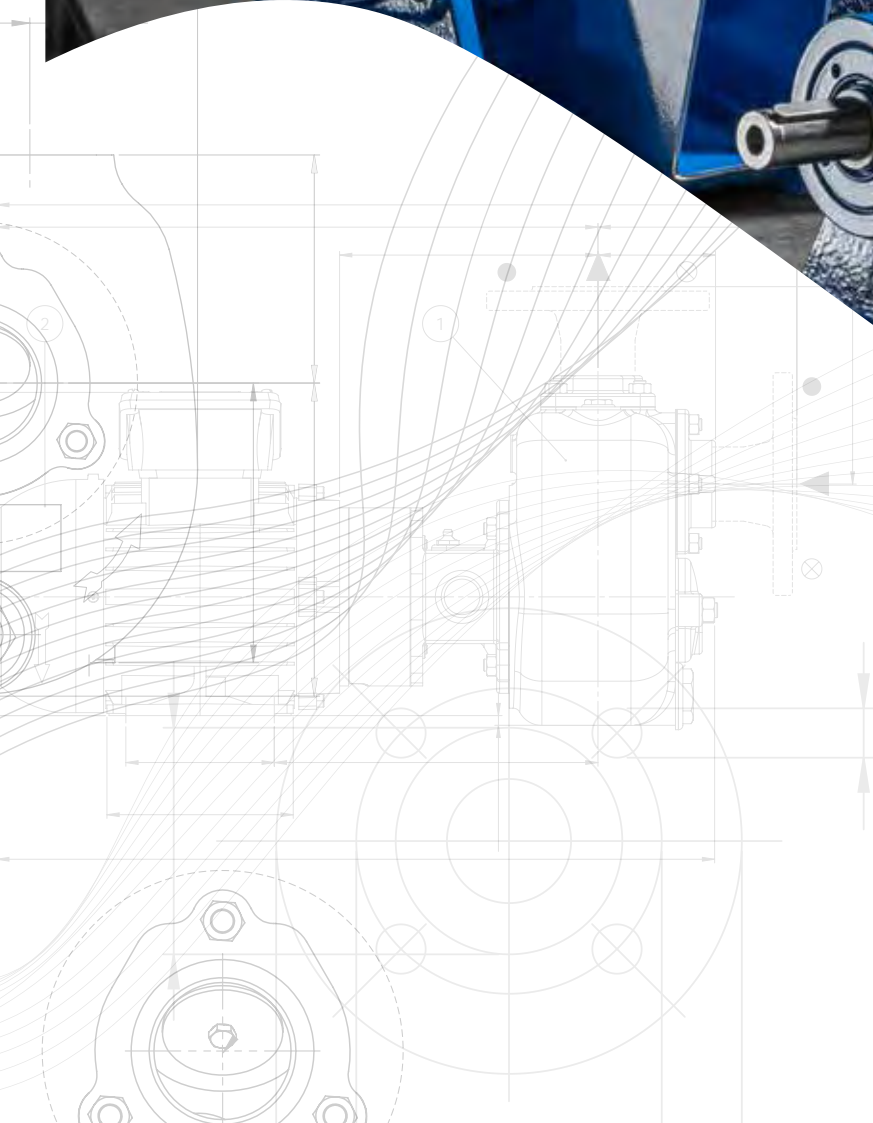
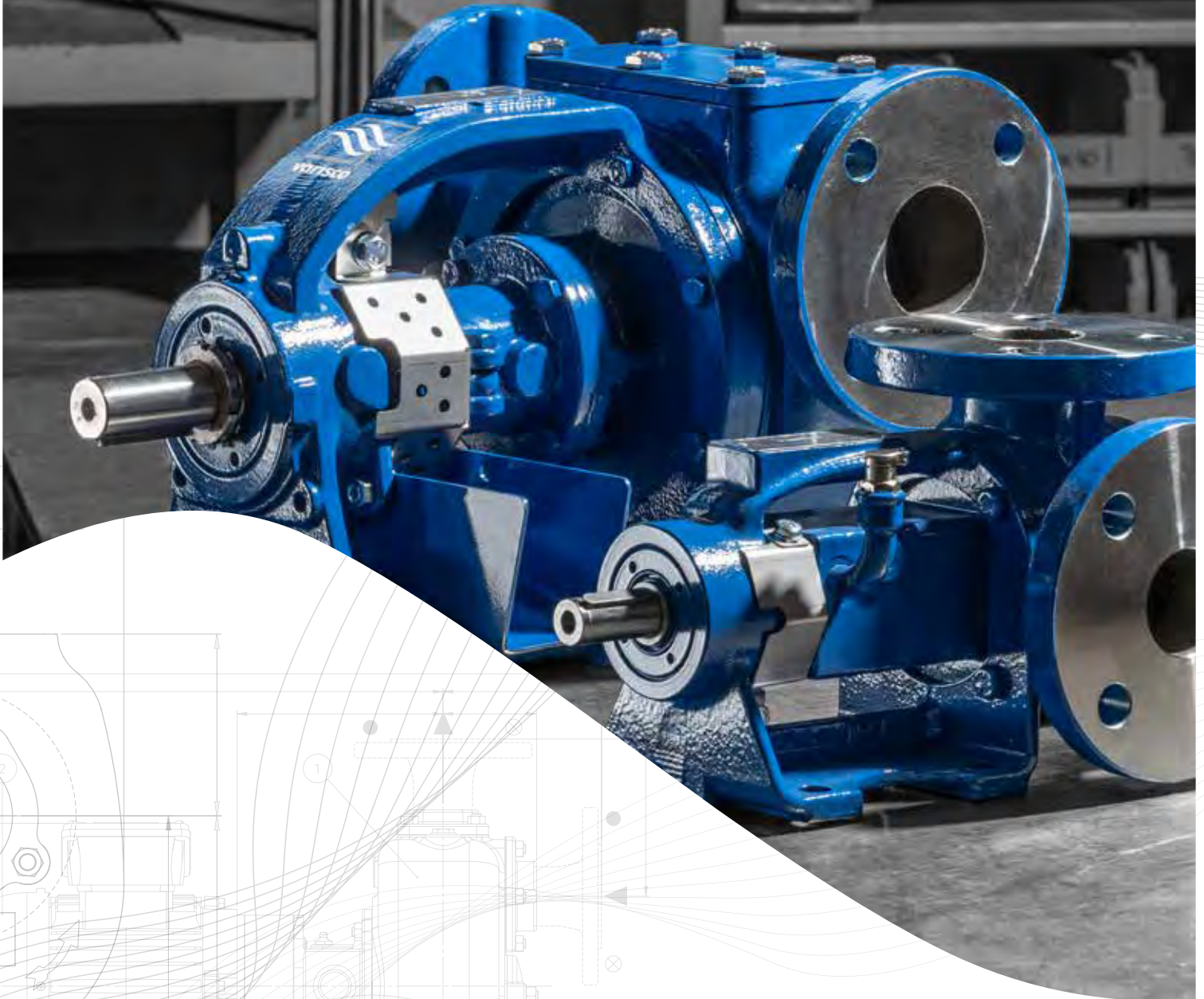

Positive displacement internal gear pumps

V and SAXMAG V Series

The **V** and **SAXMAG V** series internal gear pumps are designed to work in demanding environments and are used to transport viscous liquids even if they contain abrasive powders, as long as they do not contain solid bodies.

Active since 1932, Varisco boasts a long and consolidated experience in the design and production of pumps for use in industrial processes. All products are characterized by their reliability and quality and are tested at the internal Research and development center.



Working principle

V pumps are internal gear positive displacement rotary pumps. The flow is generated by two gears: the rotor and idler, one inside the other, separated by a crescent. As the gears rotate, liquid is drawn into the spaces created between the gears and the crescent. When the gears mesh, the liquid is forced out of the pump. The result is a smooth flow of liquid and high capacity combined with compact size.

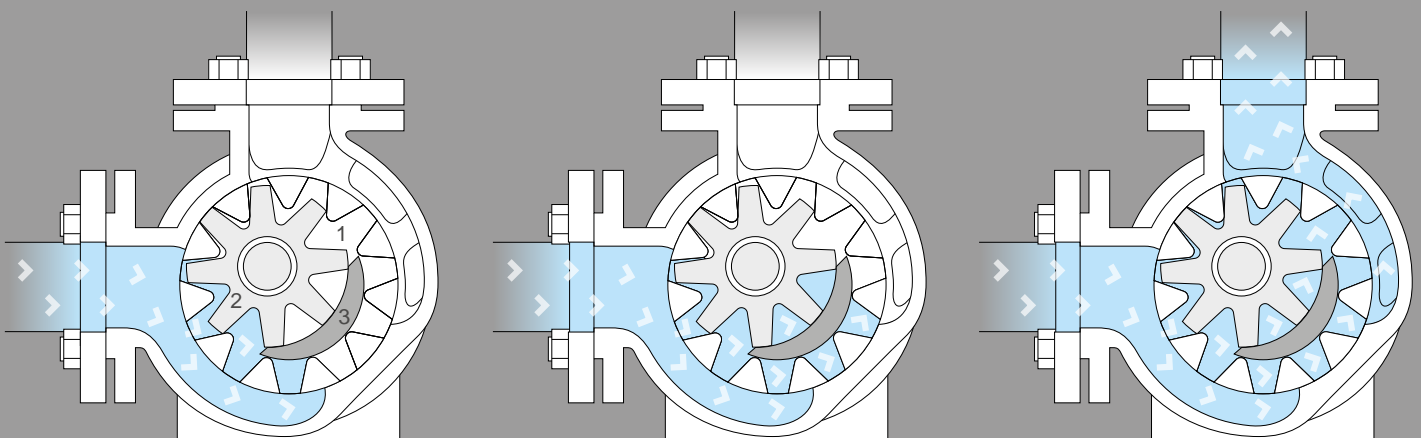

Applications



Chemical products:
solvents, acids, alkalis,
alcohols, isocyanate,
polyol, sodium silicate,
polyurethane foam,
rubbers, latex, polyester
resins

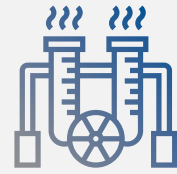

Petroleum oil products:
petrol, fuel oil, lubricating
oil, additives, crude oil



Soaps and cleaning
products: surfactants,
liquid cleaning
products, products
for personal hygiene



Adhesives: glues,
epoxy resins



Paints and inks:
printing ink,
lacquers, linings,
automotive paint,
additives

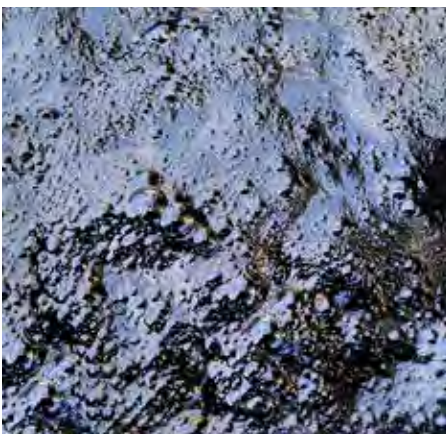

High temperature
liquids: bitumen,
pitch, tar, diathermic
oil

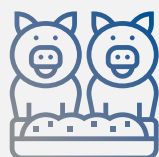

Animal feed pro-
ducts: feed, vege-
table oil, animal fats



Food products:
molasses, choco-
late, cocoa butter,
glucose *



V Series

Main characteristics of the range

V volumetric internal gear pumps are used in applications where the management of clean fluids with high viscosities is required.

They are used in all industrial applications where a delicate treatment of the pumped product is required, preventing chemical-physical alterations.

Volumetric rotary, they ensure flow rates proportional to the rotational speed and constant pulse-free flows, regardless of the back pressure.



EASY MAINTENANCE



CERTIFICATIONS:

- ATEX (ZONES 1 AND 2) 
- EC NO. 1935 / 2004
- API 676 (WITH EXCEPTIONS)

CONSTRUCTION CHARACTERISTICS

- > Axial packing, mechanical, lip, single or double seals
- > Double shaft support through large bearings for axial and radial loads and shaft and idler bushings available in cast iron, bronze, graphite, tungsten carbide
- > Dedicated ring nuts for tolerance axial adjustment
- > Shaft and idler in case-hardened steel or stainless steel

TECHNICAL DATA

Max flow rate up to 240 m³/h - 1.056 USGPM

Viscosity from 20 up to 100.000 [mm²/s - cSt]

Max pressure up to 16 bar - 232 psi

Max temperature 200°C (HT version: 300°C)
392°F max (HT version: 572°F)

Standard construction materials: cast iron, hardened cast iron, stainless steel, carbon steel

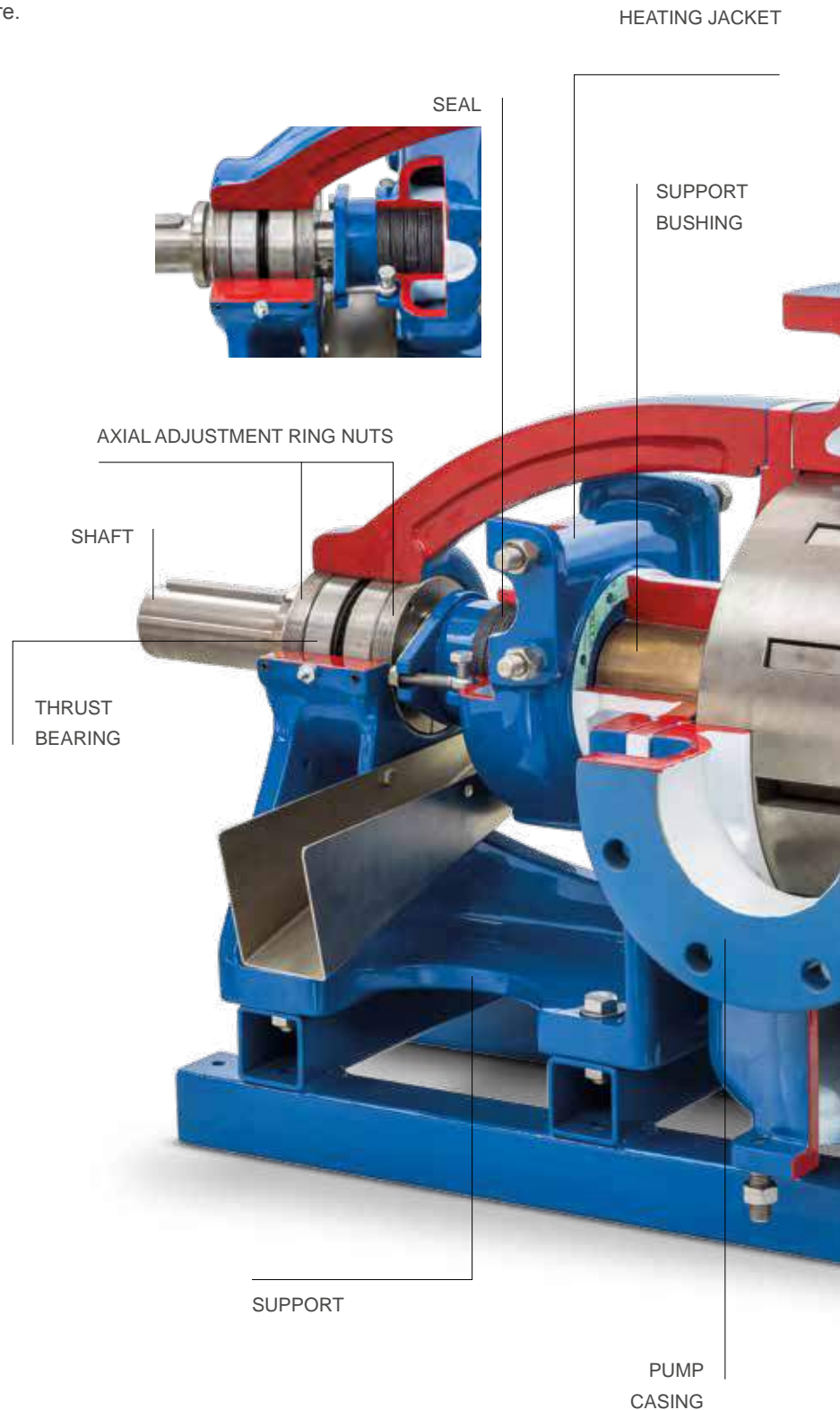



INTERNAL ROTOR

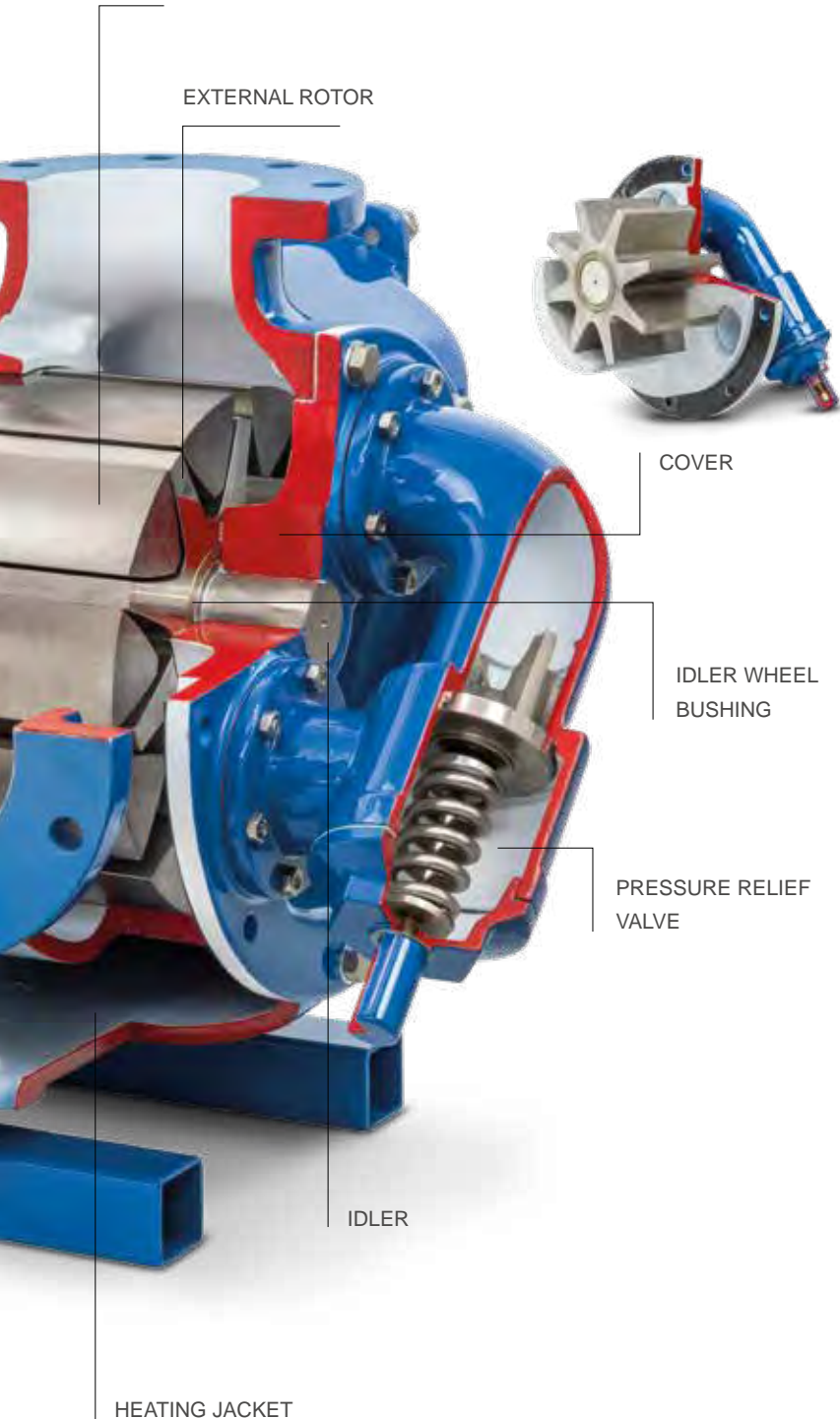

EXTERNAL ROTOR

COVER

IDLER WHEEL
BUSHING

PRESSURE RELIEF
VALVE

IDLER

HEATING JACKET

ADVANTAGES

- > Designed for **heavy-duty service** (HEAVY DUTY PUMPS)
- > **Constant flow rate**, proportional to the number of revolutions, regardless of back pressure
- > **Gentle treatment of shear-sensitive fluids** (transfer of the pumped product without crushing or mixing)
- > **Continuous flow**, pulse-free and no pressure peaks, hence no system vibrations
- > **Versatility**. With the same pump, use the rotor axis adjustment device to pump liquids with viscosities below that of water or high viscosity liquids
- > **Reversible**. By changing the direction of rotation you change the direction in which the liquid flows, keeping the features and performance unchanged.
- > The high degree of vacuum that can be obtained enables **rapid self-priming**
- > **Low NPIPr** (NPSHr)
- > Simple construction, sturdiness, long lifespan, low peripheral rotor speeds for **greater reliability**
- > **Limited and compensated wear**.
- > **Simple minimal maintenance**. Inspections and adjustments can be performed without removing the pump, the pipes or the motor
- > **UNI EN 12756** standard dimension mechanical seals (former DIN 24960 - K)
- > **Interchangeability of components** with others, having different characteristics or alternative materials.
- > **The inlets can be set up in different ways**, by turning the casing on the support.

OPTIONAL

- > Heating jackets for pump casing and seal holder that can be supplied with fluid, steam and electric resistances
- > Single, double and heated by-pass pressure relief valve



V Series

Standard set-ups

BARE SHAFT
V



BASE AND JOINT
V... BP



VERTICAL
BASE AND JOINT V...V...BP



Technical specifications

V Series	Ports		Displacement l/rev	Capacity Q max - m ³ /h	Pressure bar (max)	Speed rpm	Port position Ductile iron		Port position Stainless Steel	
	mm	in					90°	180°	90°	180°
V25-2	40	1" 1/4	0,045	4,5	16	1750	•	•	•	
V30-2	40	1" 1/4	0,082	8,4	16	1750	•	•	•	
V50-3	50	2"	0,23	15,6	16	1150	•	•	•	•
V60-2	50	2"	0,5	22	16	750	•	•		•
V70-2	80	3"	0,8	28	16	600	•	•		•
V80-2	80	3"	1,2	42	16	600	•	•		•
V85-2	100	4"	1,6	54	12	600	•			
V90-2	100	4"	2,2	54	12	425	•	•	•	
V100-2	100	4"	3,2	78	12	425	•	•	•	
V120-2	125	5"	6,5	117	8	320	•			
V151	150	6"	6,5	117	8	320			•	•
V150-2	150	6"	7,8	144	8	320	•			
V180	200	8"	12	170	10	240		•		•
V200	200	8"	16,7	240	8	240		•		•

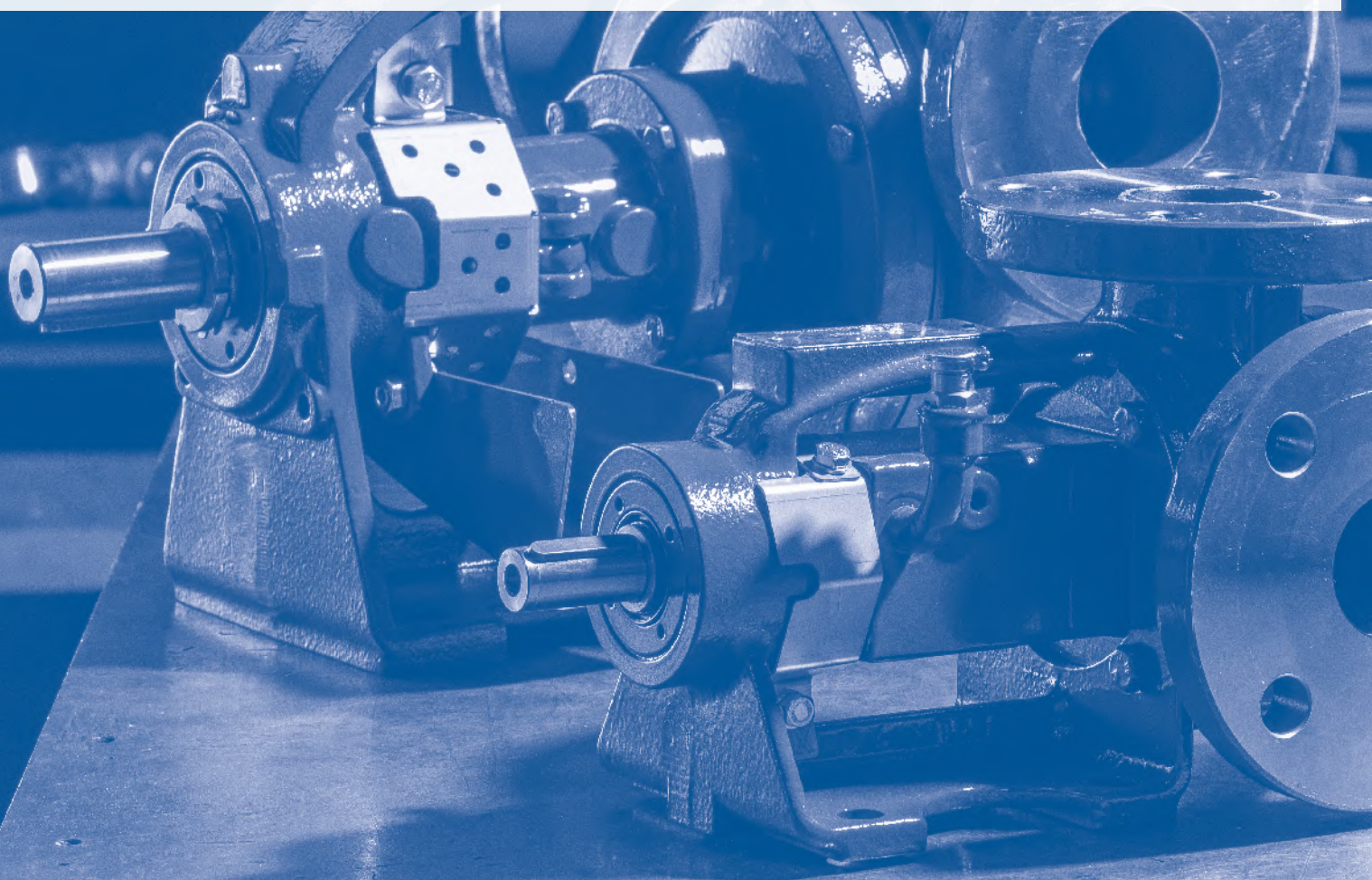

SAXMAG V

Internal gear pumps with magnetic coupling



Increasingly widespread awareness about environmental issues has encouraged enterprises to design and install technical process plants that conform to the most recent health and accident prevention standards. Certain of the national and international standards, such as ATEX 94/9, make these requirements even more stringent. This is why VARISCO decided to develop magnetic drive pumps.

WORKING PRINCIPLE

The magnetic coupling allows power to be transmitted without contact and with absolutely no leaks, thanks to the static seal. The coupling consists of an inner magnet (rotor side) and an external magnet (drive-motor side) separated by a stainless steel containment shell.

The pump shaft in the magnetic coupling is in stainless steel with a ceramic lining and is mounted on a solid carbide sliding bearing, lubricated by the pumped fluid. The heat generated by leakage through eddy currents is dissipated through dedicated cooling and lubricating grooves.



CERTIFICATIONS:

- ATEX (ZONES 1 AND 2) 
- API 676
(with exceptions)



GUARANTEED PROTECTION
FROM HAZARDOUS LEAKS

HIGH SAFETY STANDARDS EVEN
IN ATEX ENVIRONMENTS



SAXMAG HEATING JACKET



ROTOR

PUMP CASING

INTERNAL SHAFT

TECHNICAL DATA

Max flow rate up to 82 m³/h - 361 USGPM

Viscosity from 20 up to 20.000 [mm²/s - cSt]

Max pressure 16 bar - 232 psi

Max temperature 200°C

Magnetic coupling construction materials:
cobalt samarium magnets, stainless steel
internal shaft with ceramic coating,
tungsten carbide or bronze bushings,
stainless steel glass



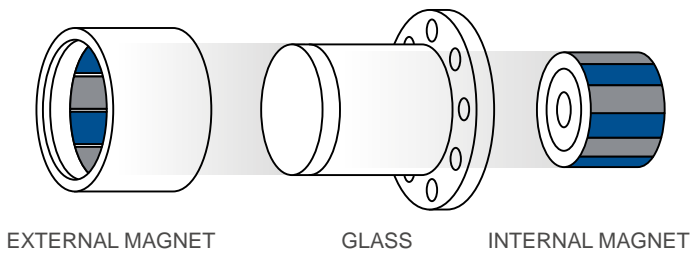

EXTERNAL MAGNET

GLASS

INTERNAL MAGNET

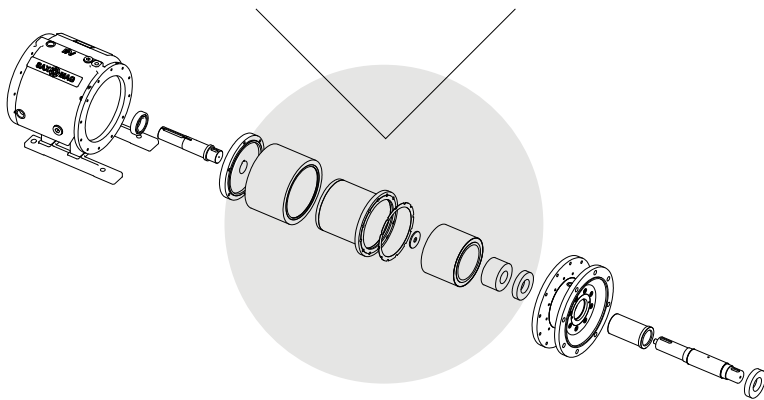

ADVANTAGES

- > **No contact** between motor shaft and pumped liquid. No seal leaks
- > Drive via **permanent magnet**
- > **Samarium cobalt magnets** for high temperatures and with high resistance to corrosion
- > Force transmission with **no leaks**
- > Transmission of **high-torque moments**
- > Compliance with **ATEX standard (zones 1 and 2)**
- > **Extremely simple replacement**
- > **Very high sealing class**
- > **Reduced system downtime**
- > **Easier maintenance** compared to versions with mechanical seal

OPTIONAL MAGNETIC JOINT

- > Atex for zone 1 and zone 2 (PT 100 mandatory and available with or without transmitter)
- > Jacketed feeder for heating and cooling

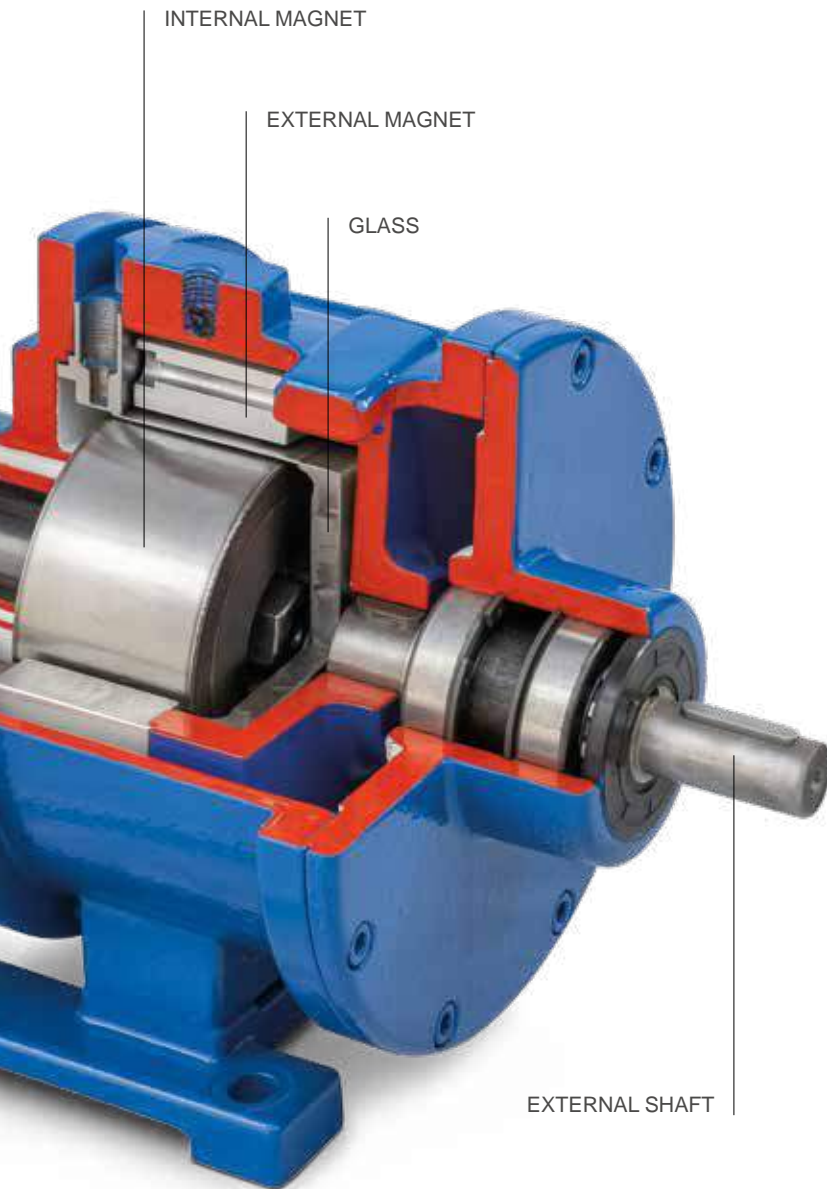

INTERNAL MAGNET

EXTERNAL MAGNET

GLASS

EXTERNAL SHAFT

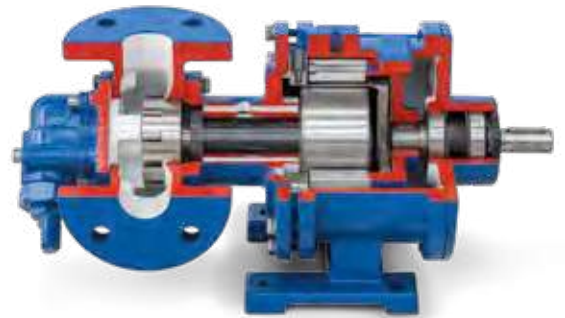

FLUIDS CONVEYED

- Additives
 - Gasoline
 - Bituminous emulsions
 - Chlorine - paraffin
 - Epoxy resin
 - Stains - paints
 - Glycerine
 - Isocyanate
 - Adhesives
 - Synthetic resins
 - Solvents
 - Methanol
 - Phenolic resins
 - Sulphates
 - Impregnating resins
 - Vinyl acetate
 - Sodium silicate
- *Viscosity: 20.000 cSt (max)



SAXMAG V

Main set-ups

**BARE SHAFT
SAXMAG... VS**



**BASE AND JOINT
SAXMAG... VE... BP**



Technical specifications

SAXMAG V Series	Ports		Flow l/min (max)	Pressure bar (max)	Torque Nm	Temperature C° (max)	Port position Ductile iron		Port position Stainless Steel	
	mm	in					90°	180°	90°	180°
Modelli										
V 25-2	40	1"1/4	75	12	50	200	•	•	•	
V 30-2	40	1"1/4	120	12	50	200	•	•	•	
V 50-3	50	2"	172	12	50 / 110	200	•	•	•	
V 60-2	50	2"	375	12	110 / 320	200	•	•		•
V 70-2	80	3"	440	12	180 / 850	200	•	•		•
V 80-2	80	3"	660	12	180 / 850	200	•	•		•
V 85-2	100	4"	900	12	320 / 850	200	•			
V 100-2	100	4"	1376	8	550 / 850	200	•	•	•	

Viscosity: 20.000 cSt (max)



V Series

Performance curves

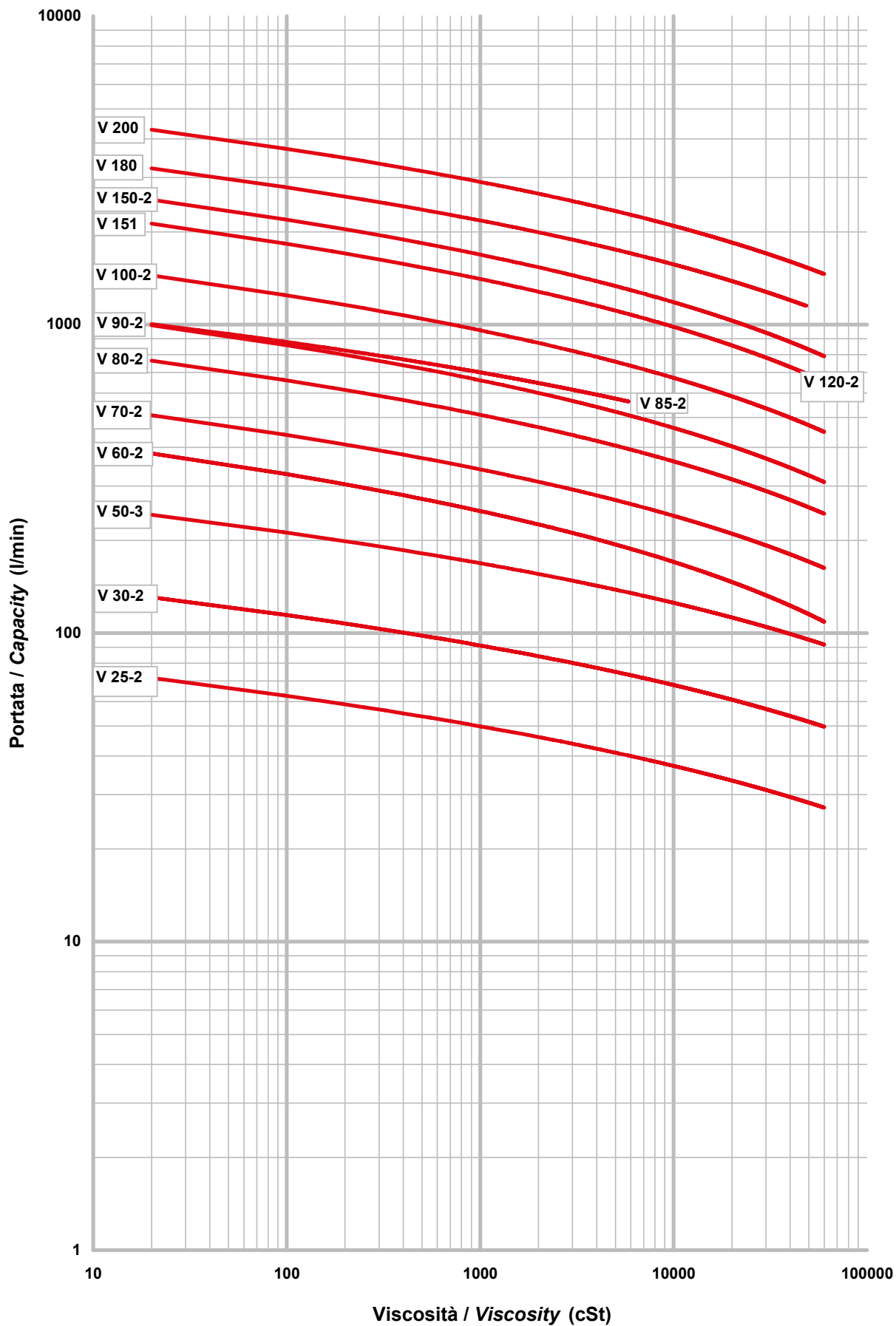

VARISCO S.r.l.

Prima strada, 37 - Zona Industriale Nord

35129 Padova - Italy

T. +39 049 8294111

export.varisco@it.atlascopco.com

www.varisco.it

