

**New!**

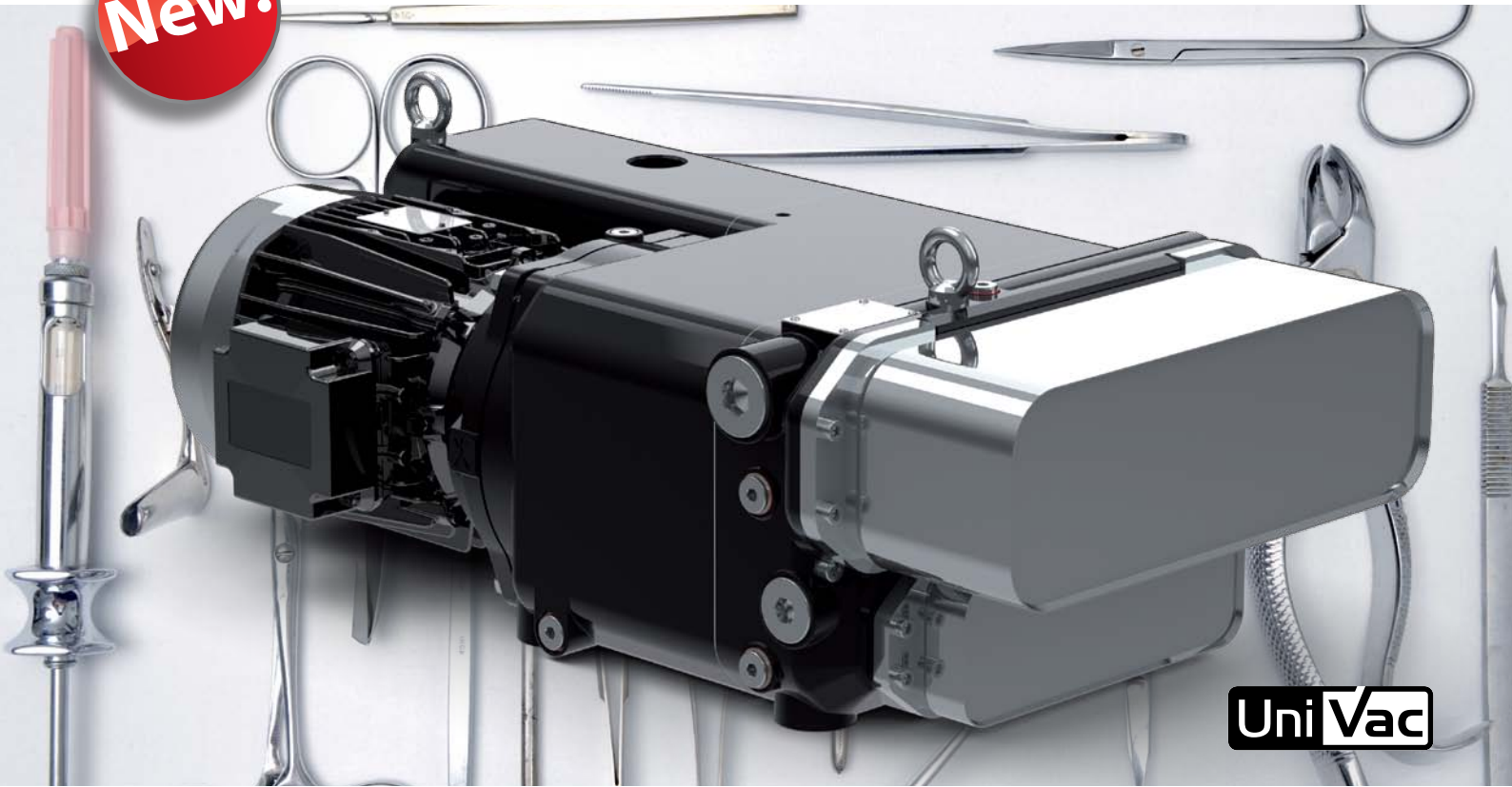

## Plug-and-Play Vacuum Units for Sterilisers

*Vacuum units with  
liquid ring vacuum pump, separator, condenser and heat exchanger  
for quick and easy installation*

## Preinstalled components in minimum space

### Liquid ring vacuum pump

Particularly low-noise two-stage pumps of the VZ series - designed as cartridge insert for easy disassembly

### Air discharge opening

Direct discharge of exhaust air to the environment

### Condenser

For media withdrawn by suction from the steriliser  
Easy disassembly when required

### Separator

For separating the gas-liquid mixture from the process

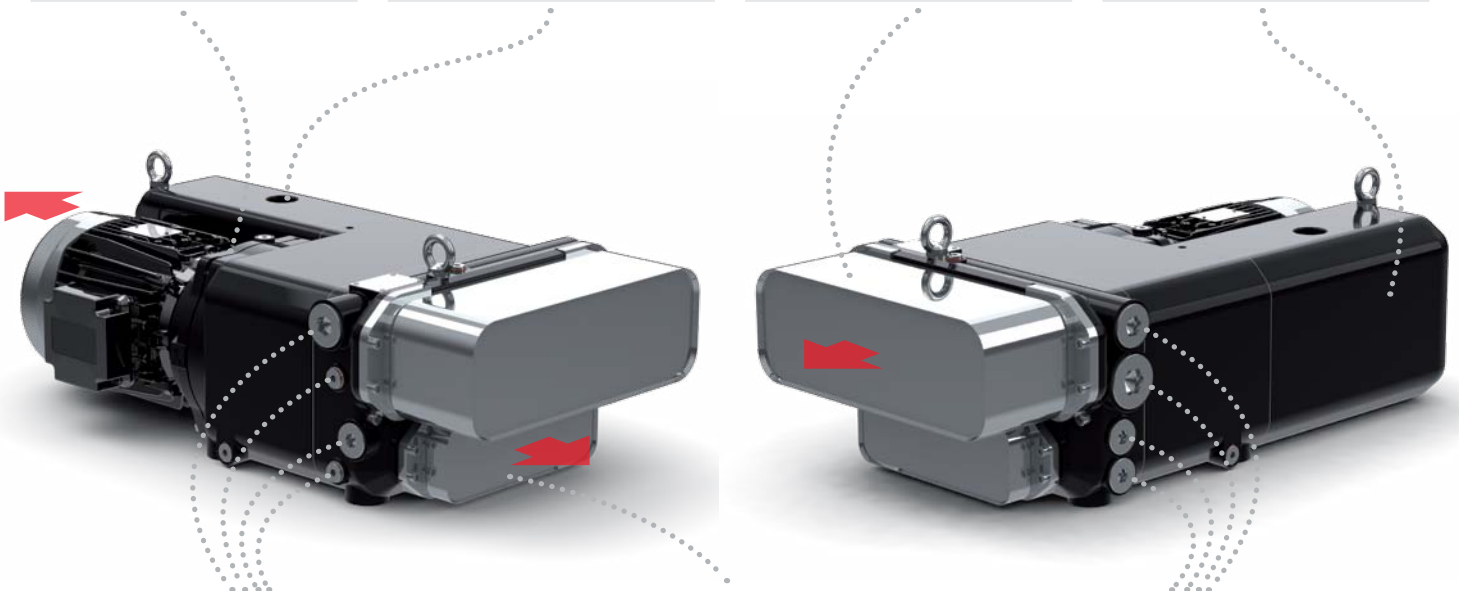

### Process fittings

Inlet of condenser cooling water  
Ventilation valve or sensor connection  
Inlet of heat exchanger cooling water  
Inlet of vacuum pump operating water

### Heat exchanger (optional)

For cooling of operating water  
Easy retrofitting or disassembly when required

### Process fittings

Outlet of condenser cooling water  
Suction connection  
Outlet of heat exchanger cooling water  
Outlet of vacuum pump operating water

# UniVac

### Fast installation

All components of the UniVac compact unit including vacuum pump, separator, condenser and optional heat exchanger are already connected to each other → simply install the UniVac unit, connect the process fittings and start right away.

### Easy maintenance

The vacuum pump is designed as cartridge insert for effortless disassembly during maintenance or replacement. Also the heat exchanger and condenser can be replaced without the need to disassemble the piping.

### Intelligent and extremely compact design

The tried-and-tested two-stage liquid ring vacuum pumps of the VZ series feature particularly low-noise operation and integrated cavitation protection.

Exhaust process air can be directly discharged to the environment. Due to its extremely compact design, the UniVac compact unit requires only minimum space inside the steriliser. If required, the optionally available heat exchanger can be retrofitted.

	UniVac-30-2	UniVac-50-2	UniVac-100-2
Width/height/depth	340 x 200 x 600	340 x 200 x 640	340 x 220 x 740
Weight	54 kg	65 kg	84 kg
Material design	cast iron	cast iron	cast iron
Power requirements	1.0 kW (50 Hz) 1.5 kW (60 Hz)	1.5 kW (50 Hz) 2.2 kW (60 Hz)	3.0 kW (50 Hz) 4.0 kW (60 Hz)
Q <sub>max</sub>	28 m <sup>3</sup> /h	49 m <sup>3</sup> /h	94 m <sup>3</sup> /h
p <sub>min</sub>	33 mbar	33 mbar	33 mbar

**speck**



Speck Pumpen Vakuumtechnik GmbH  
Regensburger Ring 6 – 8, 91154 Roth

Phone: + 49 9171 809 0  
Fax: + 49 9171 809 10

info@speck.de  
www.speck.de