



I Applications

The TLS pump is a positive displacement lobular rotating pump of a sanitary design providing high performance and maximum reliability with a reduced size.

This pump is perfect for managing all kinds of fluid, of either low or high viscosity, in the food-processing, dairies, and cosmetics industries, as well as for filtering and bottling applications. Fluids containing fragile solids such as junket, can be pumped without damage thanks to the specially designed lobes.

I Operating principles

The TLS pumps basically consist of two lobe rotors which rotate synchronously inside a casing without touching each other.

As the rotors rotate, the spaces between the lobes and the casing are successively filled with fluid, which is transported to the discharge nozzle with a fixed amount of displacement. The pumped fluid forms a continuous stream thanks to the tolerances between the lobes and the pump casing, thus ensuring an efficient pumping.

I Design and features

Close-coupled construction.

Casing and cover in stainless steel investment casting.

Tri-lobe rotors.

Health-safe design of the attachment of the rotors.

DIN connections (standard).

Sanitary mechanical seals.

Easy cleaning and maintenance.



I Materials

Parts in contact with pumped media

AISI 316L

Other parts

AISI 304

Support

GG-15

Gaskets (standard)

EPDM (FDA)

Mechanical seals (standard)

C/SiC/EPDM

Internal surface finish

Ra < 0.8 µm

External surface finish

polished



I Options

- Mech.seals in SiC/SiC, TgC/SiC, C/St.St.
- Packing with lip seal.
- Gaskets in FPM (Vitón®).
- External by-pass.
- Bi-wing lobes.
- AISI 304 drive shroud.
- Several kinds of drives and protections (gearbox drive with optional frequency converter, pulley drive speed selector).
- Trolley and/or switchboard.
- Connections: Clamp, SMS, RJT, etc.

I Technical specifications

Max. flow	41 m ³ /h / 180 GPM
Max. pressure	12bar / 174PSI
Max. working temperature	120 °C / 248 °F
Max. speed	950 rpm
Max. differential pressure	TLS 1-25, 2-40, 3-50 12 bar / 174 PSI TLS 1-40, 2-50, 3-80 7 bar / 102 PSI

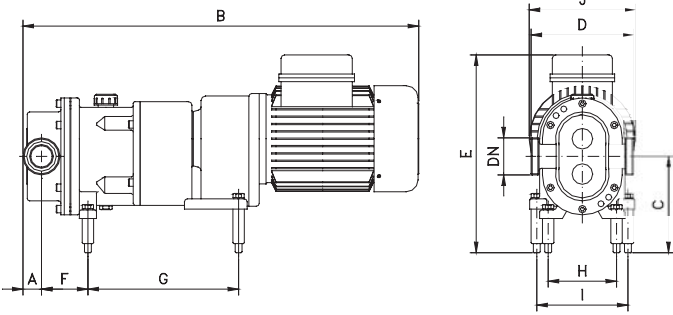

TYPE	Gear Motor		DN	A	R	C	D (*)	E	F	G	H	I	J
	kW	SIZE											
TLS 1-25	0,55 - 0,75	SK 01/80	25	26	600	150	158	295	71	275	105	105	181
	1,1 - 1,5	SK 01/90	1"		650			300					
TLS 1-40	0,75	SK 01/80	40	33	515	170	166	295	77	265	120	160	203
	1,1 - 1,5	SK 01/90			665			300					
TLS 2-40	1,1 - 1,5	SK 20/90	1 1/2"	33	695	170	190	325	82	265	120	160	203
	2,2	SK 20/100			725			355					
TLS 2-50	1,5	SK 20/90	50	39	705	227	194	325	87	265	120	160	203
	2,2	SK20/100			735			355					
TLS 3-50	2,2 - 3	SK25/100	2"	39	840	227	239	435	97	427	160	155	228
	4	SK25/112			863			445				175	
TLS 3-51	5,5	SK33/132	80	55	920	227	256	470	108	413	160	175	266
TLS 3-80	3	SK30/100			865			435				185	
	4	SK30/112	890	445	228								
TLS 3-81	5,5 - 7,5	SK33/132	3"	55	945	227	256	470	108	413	160	175	266

(*) Dimensions with DIN 11851 connections



The information contained in this brochure is for guidance only. We reserve the right to modify any material or feature without notice in advance. For further information, please, consult our web site. www.tumapumpen.at



FTLS.1.EN-0107

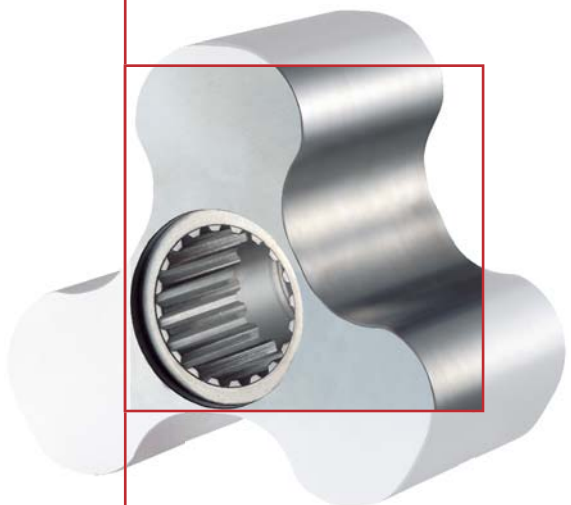

I Anwendungen

Die SLR Pumpe ist eine volumetrische Drehkolbenpumpe in steriler Ausführung für Anwendungen in der Milch-, Lebensmittel-, Getränkeindustrie und für Prozesse der pharmazeutischen- und chemischen Industrie. Sie ist hervorragend geeignet für die Förderung von niedrig bis hochviskosen Medien jeglicher Art. Die Anwendung erstreckt sich vom reinen Produkttransfer über die Beschickung von Filtern und Abfüllanlagen und weiteren Anwendungen. Flüssigkeiten die zerbrechliche Feststoffe enthalten können durch die spezielle Form der Rotoren ohne Produktbeschädigung gefördert werden.

I Funktionsprinzip

Die SLR Pumpe besteht im Wesentlichen aus zwei in einem Gehäuse gegenläufigen sich drehenden Rotoren, die sich nicht berühren.

Wenn sich die Rotoren drehen wird das Medium, das sich in den Hohlräumen zwischen dem Gehäuse und dem Rotor befindet mit einem definierten Volumen vom Druck- zu Saugstutzen befördert.

Durch die engen Toleranzen ergibt sich ein kontinuierlicher Volumenstrom mit einem hohen Wirkungsgrad.

I Konstruktionsausführung

Getriebebauausführung
 Pumpengehäuse und Rotoren in Gussausführung,
 Dreiflügelige Rotoren,
 Selbsthemmende Ausführung der Rotorenverschraubung,
 DIN Anschlüsse (Standard),
 Sterile Gleitringdichtung,
 Einfach zu reinigen und zu Warten,
 Zertifizierung nach 3A hygiene Standards.

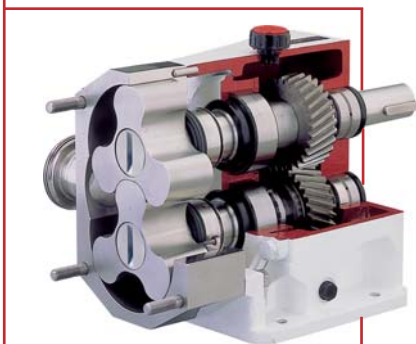

I Materialien

Produktberührende Teile:	AISI 316L
Getriebegehäuse:	GG-15
Dichtungen (Standard):	EPDM (FDA)
Gleitringdichtung (Standard):	C/SiC/EPDM
Oberfläche Produktseite:	Ra ≤ 0.8 µm
Oberflächen Außenseite:	Spiegelpoliert.



I Optionen

- Gleitringdichtung in SiC/SiC, TgC/SiC, C/St.St
- Oberfläche Produktseite in Ra_s 0.4 µm
- Gekühlte- oder Doppelte Druckbeaufschlagte Gleitringdichtung, Radialwellendichtung oder O-Ring Dichtung,
- Dichtungen in FPM (VITON®) und PTFE,
- Druckregelventil in der Gehäuseabdeckung oder externer Bypass,
- Zweiflügelige Rotoren,
- Beheizbares Gehäuse,
- Vertikale Stützenanordnung,
- Rechteckiger Trichter,
- Verschiedene Antriebe und Absicherungen (Getriebemotor mit optionalem FU oder mechanisch verstellbares Regelgetriebe)
- Edelstahlwagen mit Elektroschaltschrank,
- Anschlüsse: Clamp, SMS, RJT, ...

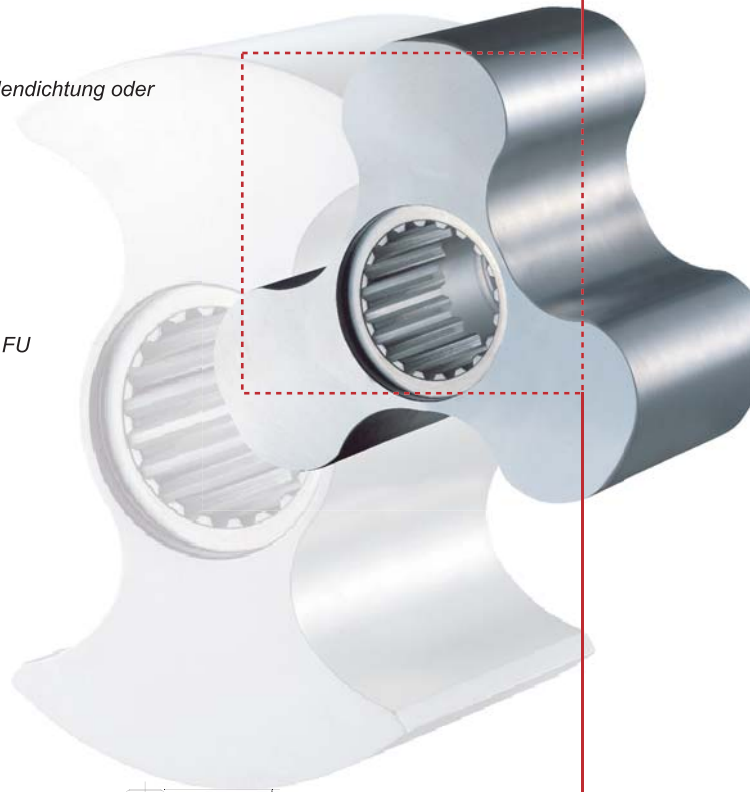

I Technische Daten

- Max. Liefergrad: 150 m³/h / 705 GPM
- Max. Förderdruck: 22 bar / 320 PSI
- Max. Betriebstemperatur: 120 °C / 248 °F
- Max. Drehzahl: 1450 U/min

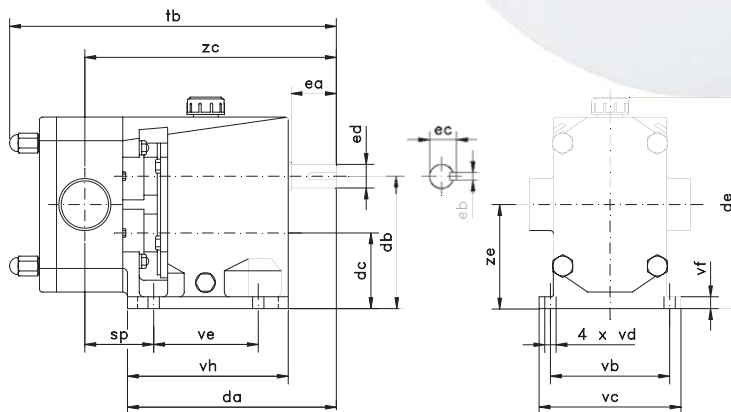

SLR	DN	da	db	dc	de	ea	eb	ec	ed	sp	tb	vb	vc	vd	ve	vf	vh	zc	ze
0-10	10-1/2"									61	253							213	
0-20	20-3/4"	160	80	40	138	30	5	16,2	14	64	261	102	118	9	50	9	65	216	60
0-25	25-1"									68	269							220	
1-20	20-3/4"									67	280							221	
1-25	25-1"	187	112	62	186	40	6	21,6	19	64	280	115	135	9	85	10	145	218	87
1-40	40-1 1/2"									70	292							224	
2-25	25-1"									80	337							267	
2-40	40-1 1/2"	221	140	78	224	50	8	27	24	74	337	125	150	11	105	12	169	261	109
2-50	50-2"									80	349							267	
3-40	40-1 1/2"									97	430							354	
3-50	50-2"	297	190	97	289	80	10	41,4	38	91	430	170	210	13	130	14	214	348	143,5
3-80	80-3"									101	452							360	
4-50	50-2"									117	627							530	
4-100	100-4"	433	240	120	366	110	16	58,9	55	92	627	260	290	18	280	15	320	505	180
4-150	150-6"									117	677							530	
5-125	125-5"									118	793							660	
5-150	150-6"	567	350	178	508	140	18	64,3	60	130	818	380	420	18	373	29	423	660	264

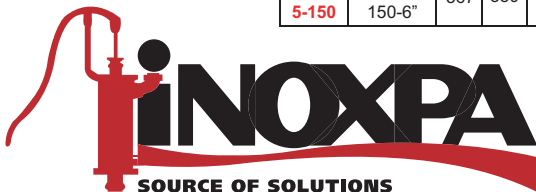

Diese Angaben sind ohne Gewähr. Änderungen möglich.
Für weitere Informationen, besuchen Sie bitte unsere Internetseite

www.tumapumpen.at



FT/SLR.1.DE-1104



TUMA PUMPENSYSTEME GMBH

Eitnergasse12

A-1230 Wien

Tel.:++431914 93 40 ; Fax.: ++431 914 93 40 16

Email:contact@tumapumpen.at

Internet:www.tumapumpen.at